



602 LATE MODEL 2024 TECHNICAL RULEBOOK

WEIGHT

1. New engine with seals - 2350 lbs.
2. One lb. per lap burn off for feature race only.
3. No lead or additional ballast bolted to any suspension component.
4. All lead must be painted white with your car number on it. 6. Lead should be securely mounted.

ENGINE: GM 602 Crate ONLY

1. These engines are sealed at the intake manifold, cylinder head, front cover, and oil pan with special twist off bolt heads. Crate engines must not be altered, modified, or changed from factory specs.
2. The penalty for anyone that tampers with or modifies any internal engine parts, changing the parts from stock as delivered sealed from the factory, will be subject to expulsion from any racing event for the remainder of the season. This may lead to a fine or a suspension from the track.
3. No changes are allowed to the engine, intake manifold, heads, valve covers, front cover, oil pan, harmonic balancer or any other part/parts on/in engine.
4. No vacuum pumps but can run exhaust evacuation system.
5. All crate engines must remain stock as they came sealed from the factory. Crate engines must not be altered, modified, or changed from the factory specs. Engine must meet GM engine specs.

CARBURETOR

1. Any 4-barrel carburetor.
2. Engine must be naturally aspirated.
3. May use one carburetor spacer, 1" maximum: 1.350" maximum including gaskets. One gasket between intake and spacer and one gasket between spacer and carburetor. Spacer may not protrude into intake in any way.

FUEL SYSTEM

1. No electric pumps permitted.
2. Pump gas or racing fuel. E-85 is ok. No methanol, alcohol, nitrous oxide, nitromethane, MTBE, hydrazine, or ethylhexanol. Any fuel tested and found to contain any of the above will be deemed illegal.
3. Any fuel with a specific gravity exceeding .744 at 60 degrees will be deemed illegal. E85 specific gravity not to exceed .786 at 60 degrees. Fuel samples may be taken at any time during an event.

IGNITION

1. Any electronic ignition system, MSD or HEI.
2. No magnetos. 3. No traction control.

TRANSMISSION

1. Standard 4-speed or automatic transmission. Aftermarket SAFETY bell housing and automatic cases permitted.
2. Bert or Brinn transmission allowed.
3. Transmissions must have two working gears, forward and a reverse gear.
4. A ball spline or roller slide transmission must run a carbon fiber driveshaft. This is a safety requirement.

REAREND

1. Standard quick change rear end permitted.
2. No titanium or exotic material axles, spools, gears, or other materials inside the rear end.
3. No open tube rear ends allowed.
4. No independent rear end suspension allowed.

ENGINE POSITION:

1. 6 ½ inches from center of ball joint to #1 spark plug, ½ inch tolerance. 50 lb weight penalty for every ½ inch out of tolerance mounted in front of water pump.

FRAME:

1. 103-inch wheelbase minimum, 1 inch tolerance.
2. Any late model chassis allowed, square tube or round tube.
3. No aluminum frames.
4. Square tube frames must be a minimum of 2" x 2" tubing; round tube must be a minimum of 1 ¾" tubing. Full racing roll cage mandatory, 1 ½ OD x .083 steel tubing minimum.

SUSPENSION

Standard late model suspension only (4 bar, swingarm, z-link, etc.)

1. No spring loaded or shock-type 4 bar rods allowed. Rods may be constructed of steel/aluminum and be solid.
2. No torsion bars.
3. One mechanical traction device allowed (5th coil, torque link, or pull bar) NOT BOTH.
4. One 90/10 shock allowed horizontally over rear end. One coil spring per corner of car. One coil spring for the 5th coil and one coil spring for the 6th coil allowed. Take up springs are permitted.
5. Any single spring ok.
6. LRF in front shock (traction shock) allowed.
7. Spring rubbers allowed.
8. Bump stops allowed.

SHOCKS

1. One (1) working shock per wheel except left rear (LRF OK). One (1) 5th Coil Shock Only. NO single adjustable or double adjustable shocks allowed. NO canister style or remote adjustable shocks permitted. NO externally adjustable shocks. Schrader Valve Shocks OK. NO Internal Bumpstops. NO Air Shocks or Spring Cages Allowed. No "Thru Rod" or Inerter Shocks.
2. One (1) 90/10 shock allowed to be mounted on top of rear end.

BODY

EAMS BODY RULES APPLY

1. Light tube bracing behind bumpers. No pipes or push bars in front of bumpers.
2. Spoiler 8-inch maximum height by 72 inches wide. Side spoiler refer to diagram.
3. All body panels must be solid, no holes, slots, or air gaps.
4. Deck height is 38" to top of the T-bar (1 inch tolerance). No bent or curved T-bars allowed.

WHEELS

1. Any wheel, 14" maximum width. Bead lock permitted, any position.
2. Wide 5 wheels and adapters permitted.

TIRES

1. Hoosier Crate D21, Crate D55.
2. Grooving and siping are ok.
3. No chemical treating or altering. Subject to durometer testing and sampling.

SAFETY

1. Approved helmet and full fire-resistant driver's suit required.
2. 50 lb weight will be added if a head and neck restraint AND full containment seat are not used.
3. All cars must have 3" lap belt and 2" shoulder harness and crotch strap MINIMUM and must be attached to roll cage. Must be less than three years old.
4. All cars must have an approved fire extinguisher, securely mounted, within easy reach of the driver. A 5 lb. halon system is recommended.

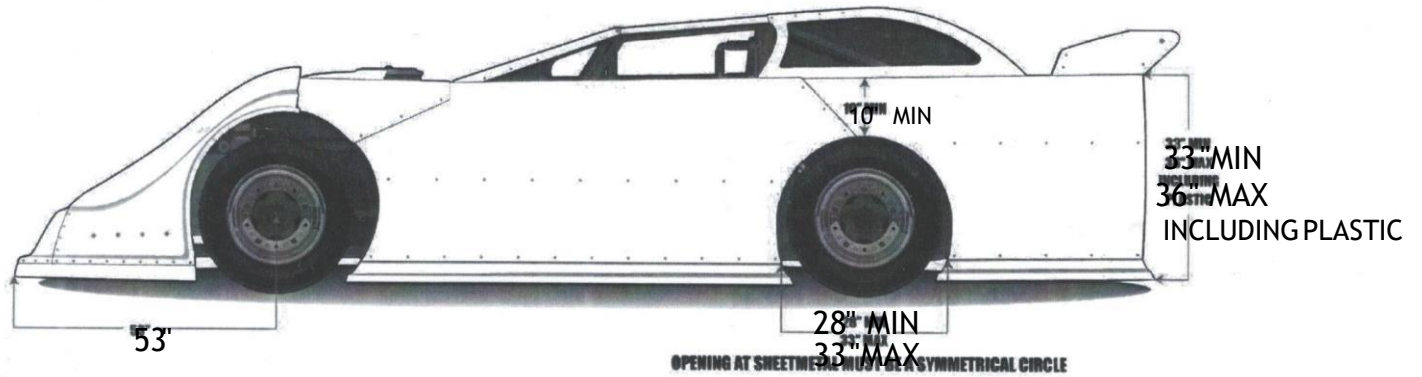

OPENING AT SHEETMETAL MUST BE A SYMMETRICAL CIRCLE

OPENING AT SHEETMETAL MUST BE A SYMMETRICAL CIRCLE

INCLUDING PLASTIC

LATE

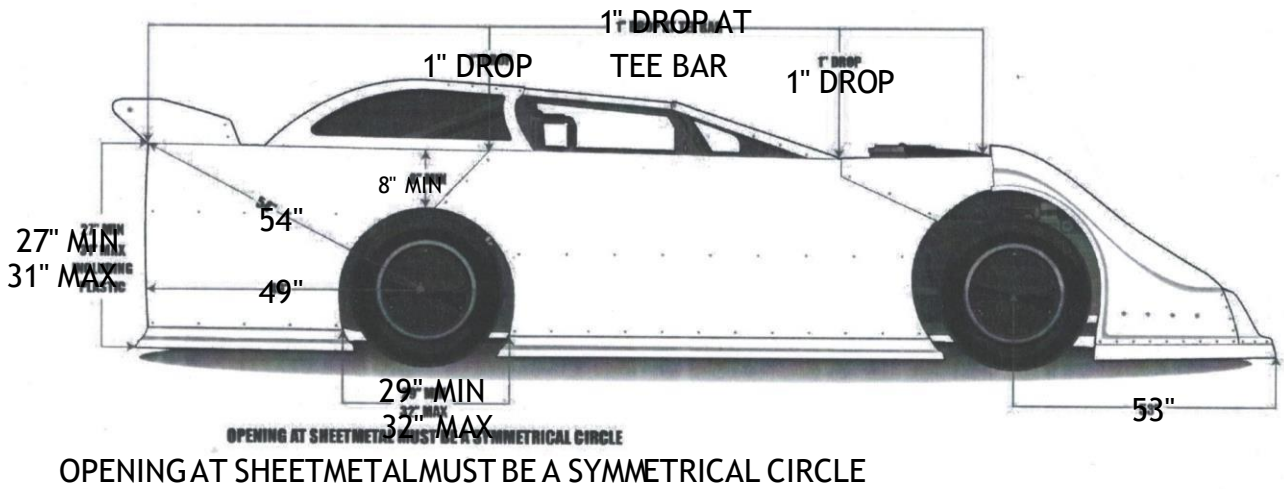

MODEL REAR QUARTER PANEL OPTIONS

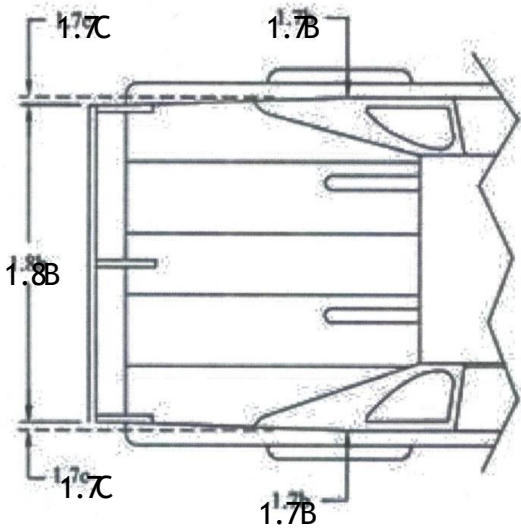

OPTION 1

REAR DECKS MUST TAPER FROM SEVENTY-SIX INCHES

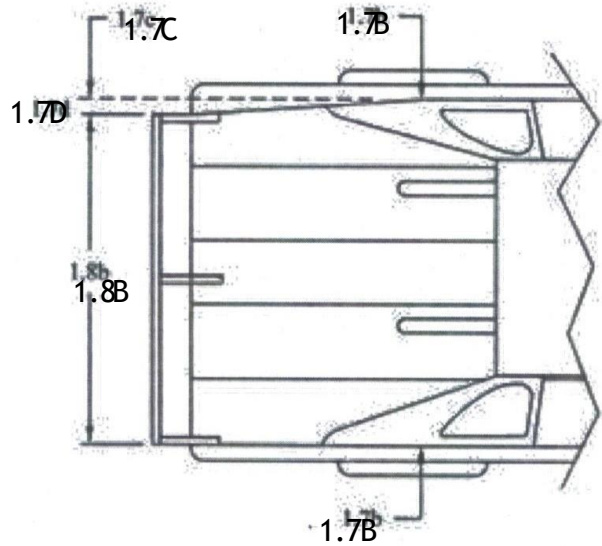

OPTION 2

REAR DECKS MUST TAPER FROM SEVENTY-SIX INCHES

(76"), AS MEASURED AT THE TOP OVER THE REAR (76"), AS MEASURED AT THE TOP OVER THE REAR HUBS, HUBS,
 UNIFORMLY BACK TO SEVENTY-TWO INCHES UNIFORMLY BACK TO SEVENTY-TWO INCHES (72") AT THE (72") AT THE
 SPOILER, EQUALLY ON BOTH SIDES SPOILER, EQUALLY ON THE LEFT SIDE ONLY
 DIRT LATE MODEL SPOILER SUPPORTS

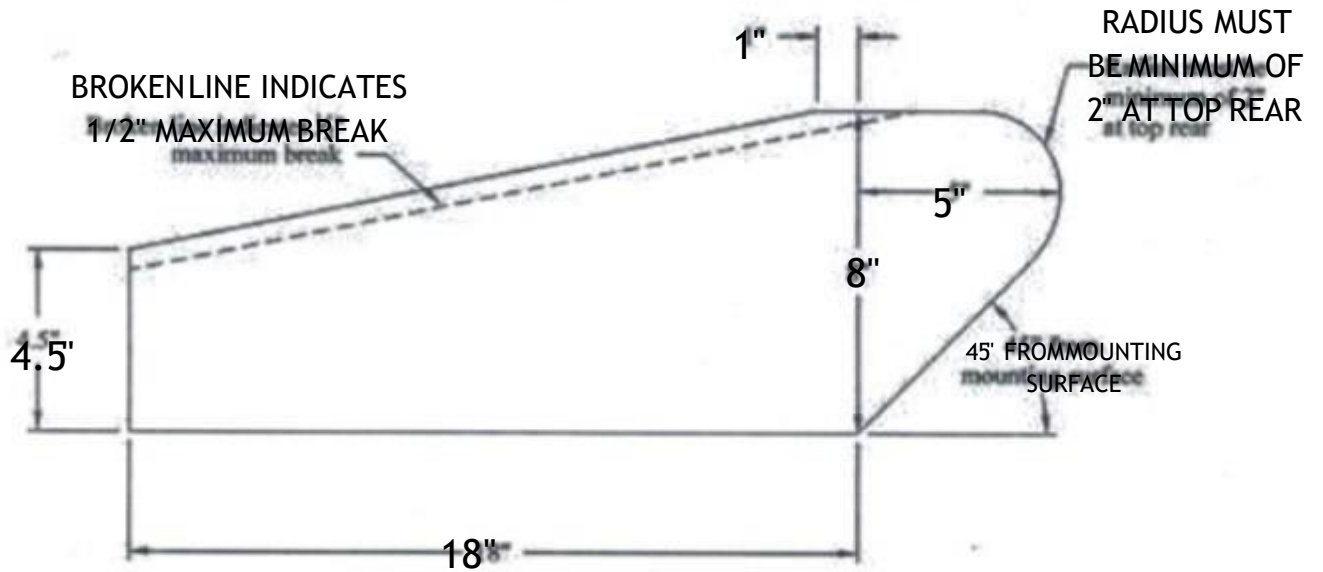

NO MORE THAN THREE (3) SPOILER SUPPORTS PERMITTED.
 FRONT EDGE OF SUPPORTS MUST BE IN LINE Must
 match template.
 DIMENSIONS HAVE ZERO TOLERANCE