



## **604 CRATE LATE MODELS 2023 TECHNICAL RULEBOOK**

### **ENGINE SETBACK**

1. Engine setback will be 6" from center of top ball joint to the most forward spark plug
2. There will be a 1" tolerance on engine setback.

### **FRAME**

1. All frames must be of steel construction
  - a. Square or rectangular frame must have a minimum of 2" by 2" material, .083 wall thickness.
  - b. Round tube frame must have a minimum of 1- $\frac{3}{4}$ " outside diameter, .083 wall thickness

### **WHEEL BASE**

1. Minimum wheelbase will be 103" with a 1" tolerance.

### **ROLL CAGE**

1. All cars must have a suitable steel roll cage protecting the driver's compartment, including headrest.
2. Side roll bars are mandatory and must extend into the door panels. A minimum of three (3) bars must be used on the left side.
3. Each bar must be at least 1- $\frac{1}{2}$ " in diameter, with a minimum material thickness of .083".
4. Roll cages must be welded to frame.

### **BODY**

#### **EAMS BODY RULES APPLY**

1. Spoilers will be measured according to total length and width of material, in any shape.
2. Gurney Flaps or Curls are allowed along the upper edge of the spoiler, but their length will be included in all measurements.

### **SAFETY**

1. Approved helmet and full fire-resistant driver's suit required.

- a. 50 lbs. Weight break for head and neck restraint.
2. All cars must have 3" lap belt and 2" shoulder harness and crotch strap MINIMUM and must be attached to roll cage. Must not be over three years old.
3. All cars must have an approved fire extinguisher, securely mounted, within easy reach of the driver. A 5 lb. halon system is recommended.
4. Full containment seat mandatory.

## APPROVED SEALED CRATE ENGINES

1. The following have been approved for use in competition:
  - a. 602 GM part number 19258602
  - b. 604 GM part number 19318604
  - c. Ford part number M-6007-D347SR
  - d. Other manufacturers- sealed crate engines with similar horsepower rating (such as Dodge) may be allowed as soon as they are available and have been approved for competition by EAMS officials.
2. GM Engines may be purchased at any GM dealer.
3. Ford Engines may be purchased at any Ford dealer.
4. Sealed engines must remain intact and may not be tampered with. Any seals that have been removed or tampered with will make the engine illegal and not eligible for competition at EAMS.
5. No changes are allowed to the engine (intake manifold, heads, valve covers, oil pan, harmonic balancer or any other part(s) on/in the engine. **Crate Engines must not be altered, modified, or changed from factory specs.**
6. No vacuum pumps.
7. All crate engines must be sealed with factory GM bolts or Crate USA seals. Other series seals may be allowed if they can be verified for authenticity. No R/M bolts.

## CRANKING COMPRESSION

1. All crate engines will have a maximum cranking pressure of 200psi.
2. Any engine over 200psi will be illegal for use at EAMS.

## WATER PUMP

1. Cast or aluminum water pump permitted.
2. No electric water pumps.

## FUEL PUMP

1. Mechanical pump only- no electric pump

## DISTRIBUTOR

1. Any ignition except for magnetos and coil pack distributor less ignition systems. Magnetos and coil pack distributor less ignition systems are not allowed.

## CARBURETOR

1. One four-barrel carburetor only, of any manufacturer.
2. Engine must be naturally aspirated.

3. May use one carburetor spacer.
  - a. 602 may use a 2-inch total thickness - .040 tolerance
  - b. 604 may use a 1-inch total thickness - .040 tolerance
  - c. D347SR may use a 1-inch total thickness - .040 tolerance
  - d. No part of spacer may enter intake plenum
4. May use 2 standard one-piece paper gaskets (maximum 0.070 inch thick) - one gasket between intake to spacer and one gasket between spacer to carburetor.

## **STARTER**

1. All cars must have a starter in working order.

## **BRAKES**

1. Four-wheel disc brakes permitted.
2. No carbon fiber brake parts allowed.

## **FUEL CELL/FUEL**

1. An approved fuel cell (32 gallon maximum) must be securely mounted in the trunk area of the car, inside a .20-gauge metal box supported by a minimum of two 2" by 1/8" steel straps.
2. All fuel cells must be completely visible from the rear of the car.
3. Fuel cell must not be mounted lower than bottom of quick-change rear end.
4. Pump gas or racing fuel only. (*RACING FUEL AVAILABLE AT TRACK*)
  - a. Pump gas may contain up to 10% ethanol as allowed by law.
  - b. Gas must pass acid test
  - c. E85 Fuel is allowed.
  - d. Fuel must check within 1% at any time checked, (MIN 84% ETHANOL- MAX 86%)
5. No alcohol, methanol, nitrous oxide, or chemical additives including, but not limited to, propylene oxide, nitromethane, nitro propane, or any nitrate additives.

## **TRANSMISSION**

1. Must have at least one forward and one reverse gear in working order.
2. Automatic transmission permitted-must have torque converter or manual fluid bypass valve system.
3. No straight drives or in and out boxes.

## **WHEELS**

1. Any brand or type of wheel allowed- must be mounted with lug nuts.
2. No knock-off or center lock wheels.
3. Maximum wheel width- 14"

## TIRES

1. Hoosier Spec 1350, Spec 1600, Crate 21, and Crate 55 allowed or equivalent.
2. Grooving, siping, and buffing tires permitted.
3. All numbers, codes, and manufacturer names must remain visible on the tire. No grinding off of numbers, codes or names. Any tire that has been altered will be illegal.
4. No tire softeners or conditioners permitted.
  - a. Tires may not be altered using any natural or unnatural, hazardous or nonhazardous, components or chemicals that affect the factory set baseline settings of a given tire.
  - b. **ALL competitors are subject to tire inspections.**
5. Tires available on race night or call CSR 334-297-2594.

## WEIGHT

1. All cars must have specified weight posted on top left side of roof.
  - a. GM Crate Engine 602- 2200 lbs. Rebuilt 602 – 2250 lbs.
  - b. GM Crate Engine 604- 2300 lbs. Rebuilt 604 - 2350 lbs.
  - c. Ford Crate Engine D347SR- 2300 lbs.
2. Minimum weight will be measured with driver in car.
3. Attached weight must be securely bolted to frame with ½” or larger bolts, and painted white or silver with car number clearly painted on them.
4. No weight may be attached to rear bumper.
5. No lead pellets or liquid weight.
6. No driver operated weight adjustment devices.
7. One pound per lap weight allowance after race.
8. 50 lb weight will be added if a head and neck restraint AND full containment seat are not used.
9. Track reserves the right to adjust weights in interest of competition should it be deemed necessary.

## REPAIR & REBUILD PROGRAM

EAMS has in place a network of Authorized Crate Engine Repair/Rebuild Centers. All repairs and rebuilds must be done by one of these Authorized Repair/Rebuild Centers. The engine will be repaired, or rebuilt, and sealed according to the specific guidelines provided by the manufacturer of the engine. *Please call Clint Smith at 404-925-1888 for a complete list of the Authorized Repair/Rebuild Centers.*

## CRATE LATE MODEL PROTEST FEES (See also General Rules)

Protest fees are as follows:

- \$600.00 One Head (Track retains \$100)
- \$600.00 Oil Pan (Track retains \$100)
- \$100.00 Engine Setback (1” tolerance)
- \$100 Gas

Any item not listed in the protest fees above is considered a visual protest item and must be protested **before** the feature race.

Any Crate Engine protested must be reassembled and resealed by one of the Authorized Repair/Rebuild Centers approved by EAMS.

### PENALTIES FOR CRATE ENGINE INFRACTION

Disqualification from race, 0 points, \$0.00 in prize money awarded during the race, and a \$300.00 fine. *Fines must be paid before either car or driver can return to competition at EAMS.*

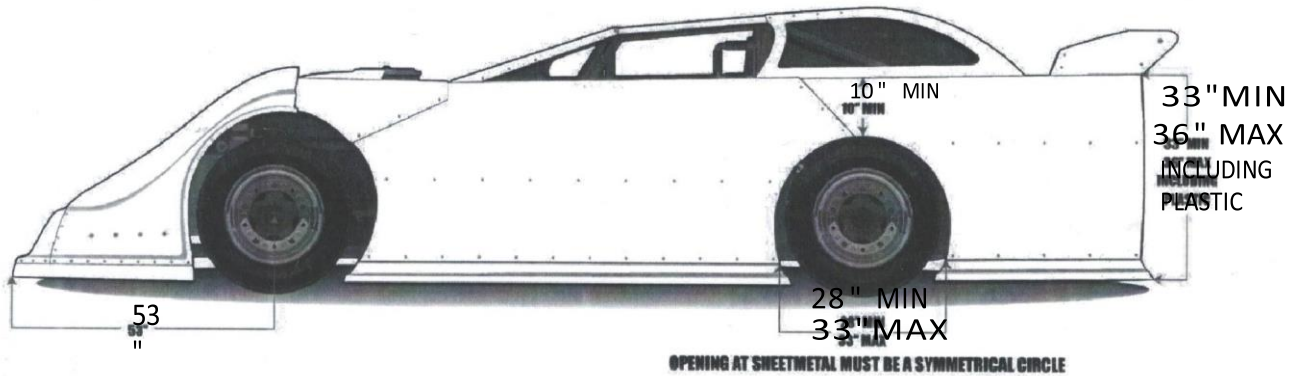

OPENING AT SHEETMETAL MUST BE A SYMMETRICAL CIRCLE

1" DROP AT TEE BAR      1" DROP      1" DROP

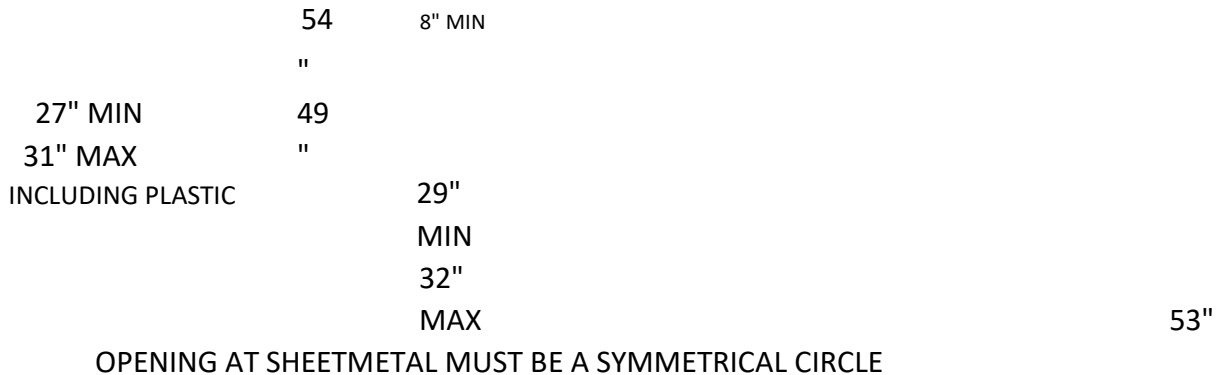

### LATE MODEL REAR QUARTER PANEL OPTIONS

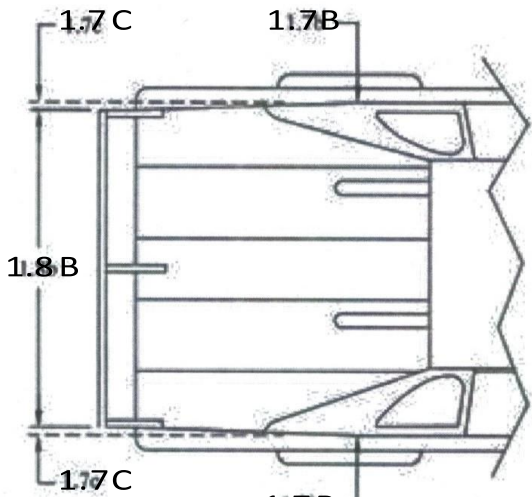

OPTION 1

REAR DECKS MUST TAPER FROM SEVENTY-SIX INCHES (76"), AS MEASURED AT THE TOP OVER THE REAR HUBS, UNIFORMLY BACK TO

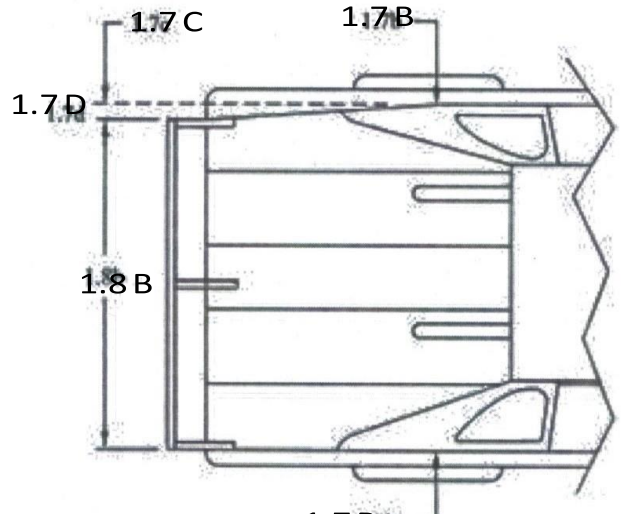

OPTION 2

REAR DECKS MUST TAPER FROM SEVENTY-SIX INCHES (76"), AS MEASURED AT THE TOP OVER

SEVENTY-TWO INCHES (72") AT THE SPOILER,  
EQUALLY ON BOTH SIDES

THE REAR HUBS, UNIFORMLY BACK TO SEVENTY-  
TWO INCHES (72") AT THE SPOILER, EQUALLY ON  
THE LEFT SIDE ONLY

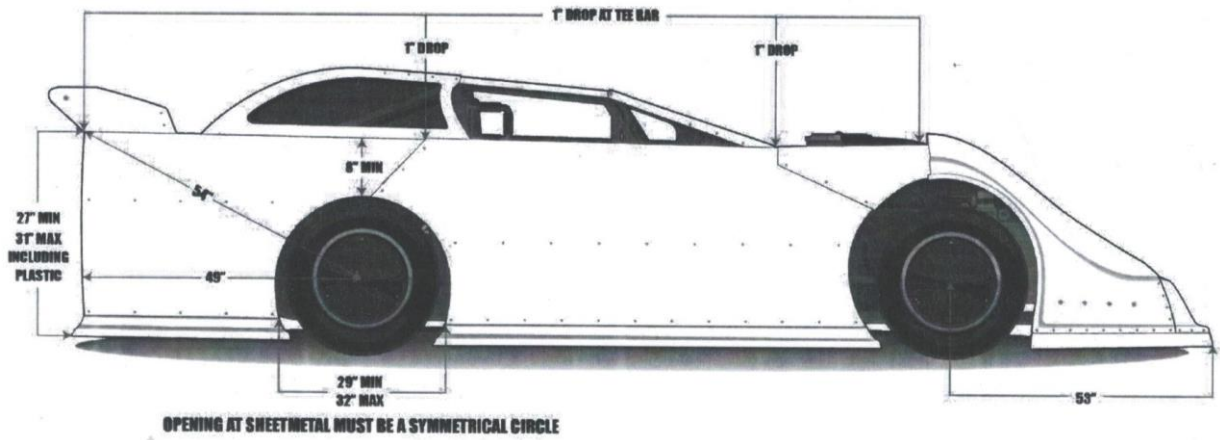

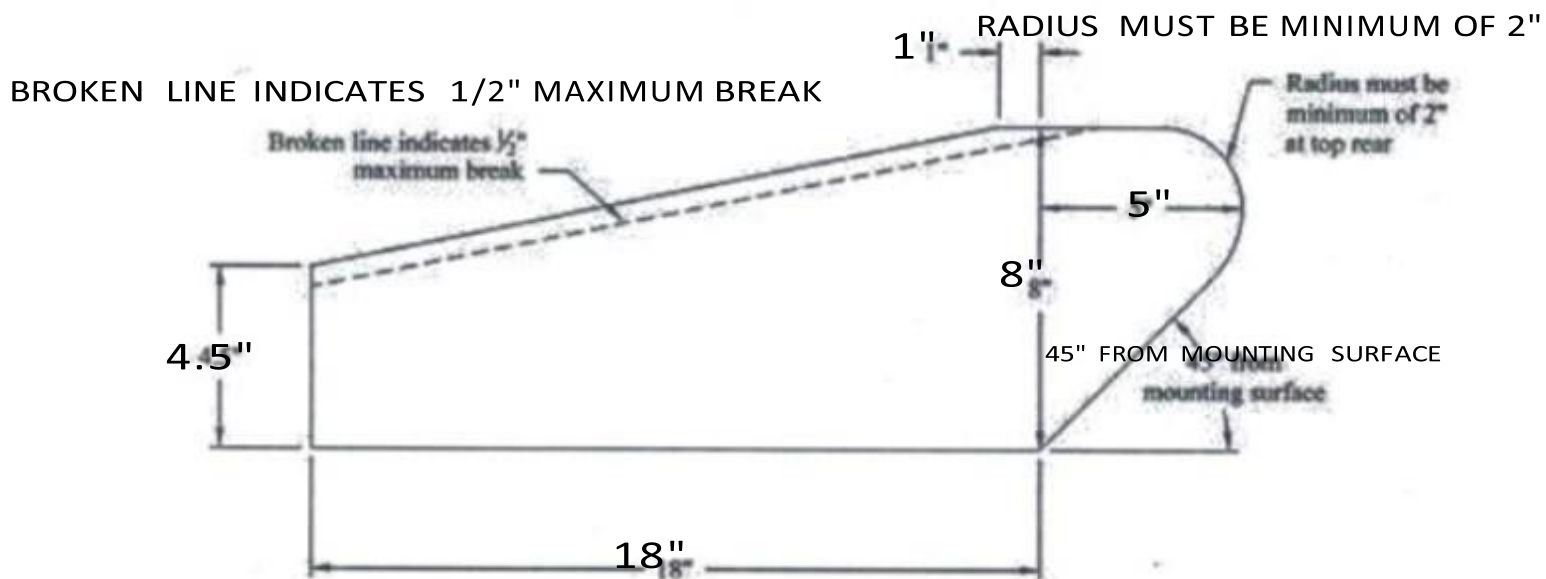

DIRT LATE MODEL SPOILER SUPPORTS

NO MORE THAN THREE (3) SPOILER SUPPORTS PERMITTED.  
FRONT EDGE OF SUPPORTS MUST BE IN LINE Must match  
template.

DIMENSIONS HAVE ZERO TOLERANCE